

Length ± 3.0M

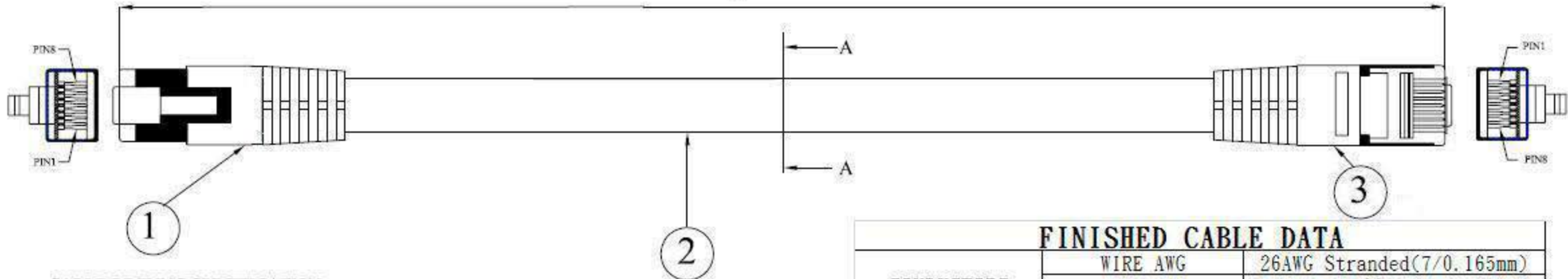

CABLE BINDING SPECIFICATION

NOTE : EACH CABLE PACKED IN A PE BAG

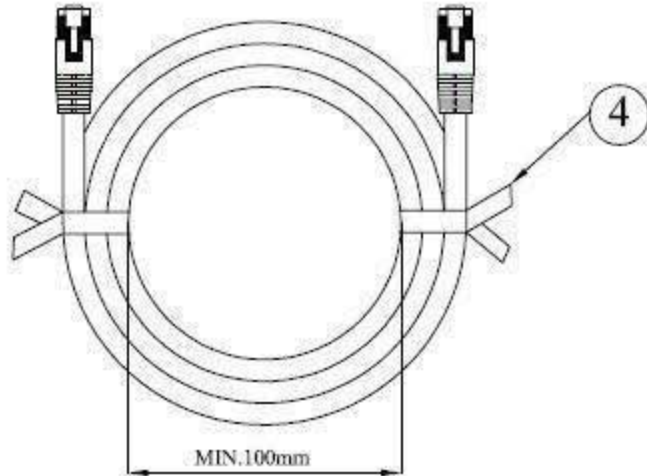

SECTION A-A



T568B WIRING DIAGRAM

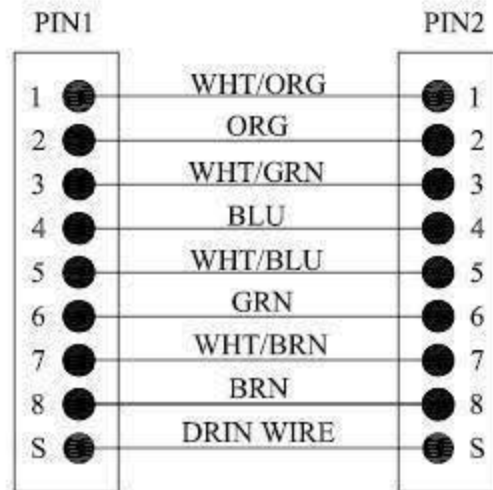

FINISHED CABLE DATA

CONDUCTORS	WIRE AWG	26AWG Stranded(7/0.165mm)
	MATERIAL	COPPER
	PLATING	BARE COPPER
INSULATION	MATERIAL	POLYOLEFIN
	OVERALL DIAMETER	0.89(mm) ±0.02
CENTRAL ELEMENT	TYPE	PE CROSS SEPARATOR
DRAIN WIRE	WIRE AWG	Starnded(7/0.16mm)
	MATERIAL	TINNED BARE COPPER
SHIELD	MATERIAL	AL/FOIL POLYSTER
	MATERIAL	ALU/MYLAR FOIL
JACKET	THICKNESS	min 0.47mm
	OVERALL DIAMETER	6.19mm ±0.2
	COLOR	GREY(071)

NO.	DESCRIPTION	MATERIAL	FINISH	Q'TY	PART NO.
1	50U"RJ45 PLUG (SHIELDED)	PC		2	06-PO-88501
2	CABLE	PE/PVC	CAT.6	1	66204
3	MOLDING S.R.	PVC		2	06-SR-60XX6
4	MAGIC BAND	PVC		2	06-MG-0010

PRINTING:

Delta△SupremeNet△250△66204△4PAIRS△26AWG△FTP△GIGABIT△PATCH△CABLE△

	CUSTOMER DRAWING			
	STP-63	DWN	IRIS	
		CHK	KEN	
ITEM	AWG*4P UTP CAT 6 PATCH CORD	FINISH	APVD	JIM FAN
			DMENSION	N/A
DWG NO		SCALE	N/A	SIZE
			A4	SHEET
			1/1	REV
				1.0